

Verktug för invändig svarvning
Låsbricka, Automatstål

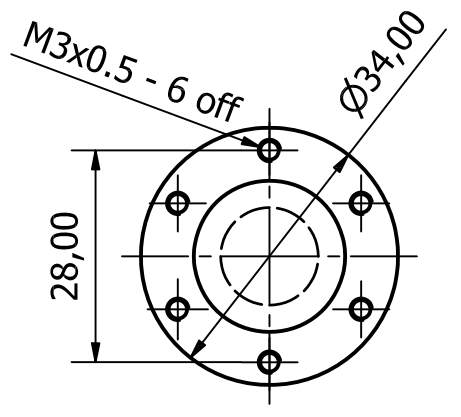

Verktug för invändig svarvning, Automatstål

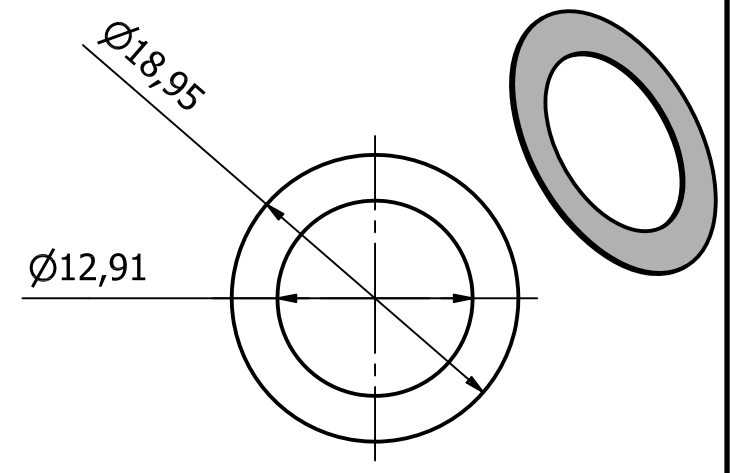
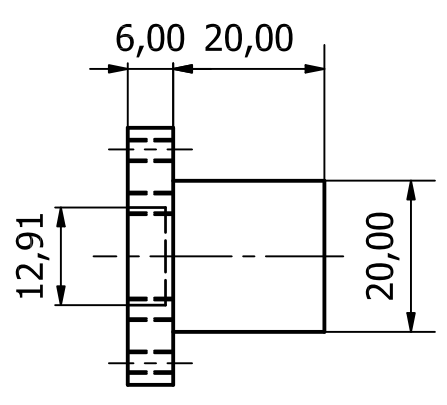

Schims T= 0,2 0,15, 0,1 & 0,05
Mässingsplåt svarvas ur plattor
21x21 i vidstående verktyg,
centreras mellan hål.

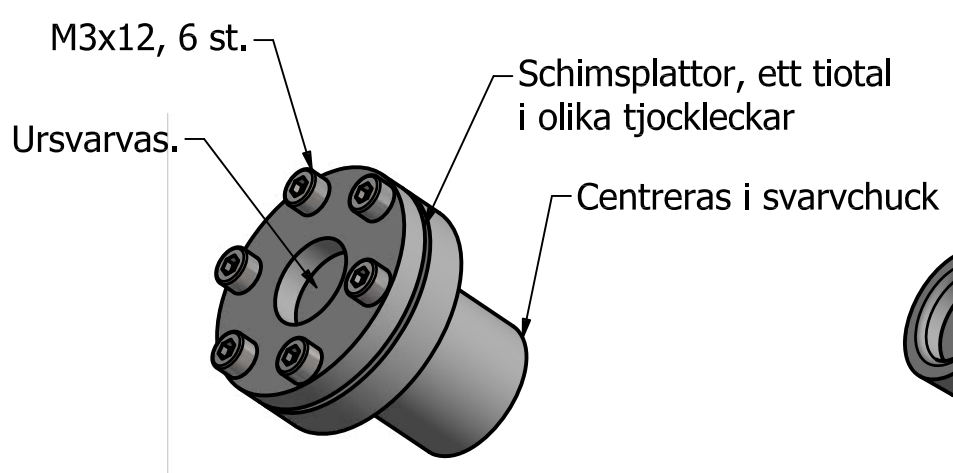

Svarvning av schims invändigt

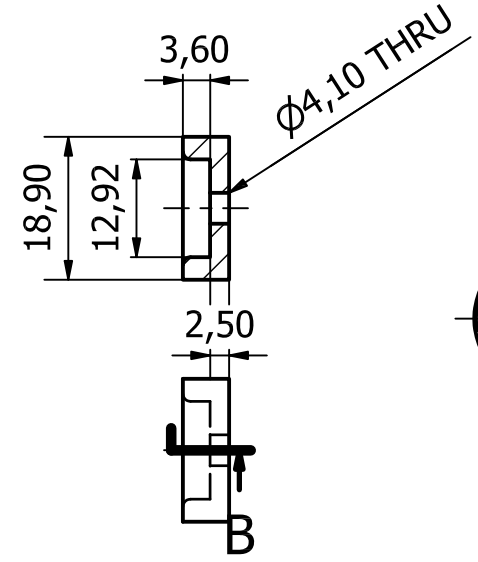

Låsbricka utvändig svarvning

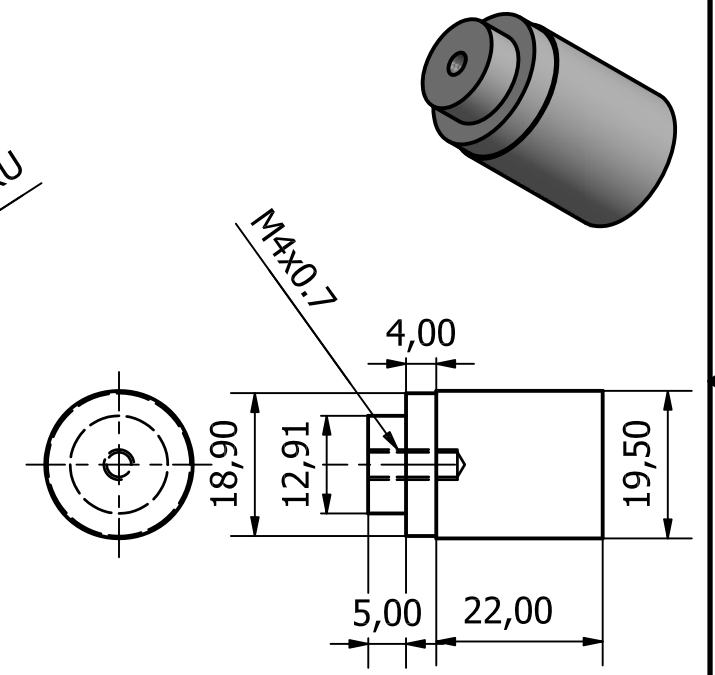

Verktug utvändig svarvning, Automatstål

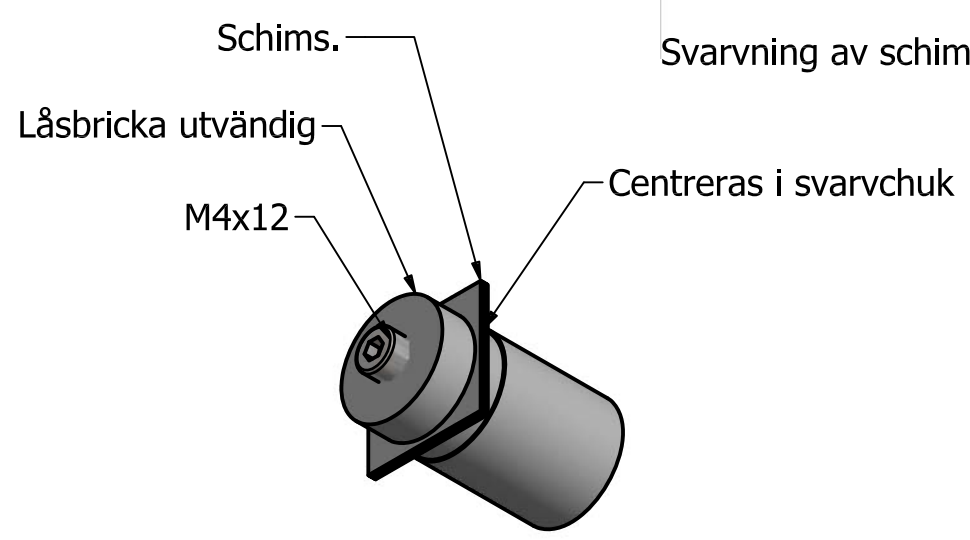

Svarvning av schims utvändigt

Designed by Leif Persson	Datafil Mcar/1,5-2,5/1,5/Kapu/Cylinderenhet/Schims topp	Date
Leif Persson Greviegatan 25, 235 33 Vellinge leif@nordicbellows.se		Detalj. Schims inklusive erktug